

Design of self-oscillating electronic ballast with high efficiency and high power factor

Juárez M.A., Martínez P.R., Vázquez G, Sosa J.M, Valtierra M * Ponce M.

Higher Technological Institute of Irapuato. ITESI

*National Center of Research and Technological Development , Cuernavaca, México

mario_a_juarez@ieee.org

Resumen

Este artículo presenta un diseño de un balastro electrónico para lámparas fluorescentes. Un balastro electrónico auto-oscilante de bajo costo y alta eficiencia con un alto factor de potencia y baja distorsión armónica total.

Parte de esta alta eficiencia es obtenida por medio de un convertidor conformador de corriente el cual procesa parte de la energía entregada a la lámpara de manera directa, por lo tanto la eficiencia de este convertidor es más alta que las topologías convencionales. Para obtener más eficiencia un convertidor Clase D trabaja en conmutación de corriente cero durante el encendido y el apagado es propuesto.

El convertidor Clase D y el conformador de corriente son controlados por medio de un circuito de auto-oscilación, de esta manera el balastro propuesto no emplea circuitos integrados. Finalmente la condición de estabilización obtiene a través del análisis del capacitor de salida (C_o) del convertidor.

Palabras clave: Balastro electrónico, corrección del factor de potencia, lámparas fluorescentes.

Abstract

This paper presents the design guidelines of electronic ballast for fluorescent lamps. Low-cost high-efficient self-oscillating electronic ballast with high power factor and low THD (total harmonic distortion) is presented.

Part of this high efficiency is obtained through input current shaper converter which only process part of the energy delivered to the lamp; therefore, the efficiency is higher than the conventional topologies. In order to get the highest efficiency a class-D converter working under both ON-OFF zero current switching is proposed.

The Class-D converter and input current shaper converter are controlled by an extra winding in the self-oscillating circuit. So, there are no integrated circuits in the proposed electronic ballast. Finally, a necessary and sufficient condition for the system stability is obtained through the analysis of the output capacitor C_o .

Key words: electronics ballast, fluorescents lamps, power factor correction.

I. - Introduction

Nowadays, the use of electronic ballast is very common due to their well know excellent advantages; in fact, they still are investigated for getting more efficiency and lower costs. The self-oscillating electronic ballasts (SOEB) are characterized by circuit simplicity, low cost, and robustness [1], [2]. The traditional way for supplying self-oscillating electronic ballast is through a rectifier followed by a bulk capacitor; however, this structure drains a current waveform with high harmonic content and low power factor.

Currently, international regulations regarding harmonics pollution demand lower limits in the harmonic currents. So, it is necessary to use an extra power conversion stages to improve the total harmonic distortion on the input current. However, extra stages mean lower efficiency, higher complexity, and more components; consequently, higher costs. Many researches have proposed alternatives to improve the harmonic content on the input current but they have the same aforementioned drawbacks.

Normally, resonant tank of SOEB is designed in so way that it represents inductive impedance in series with the lamp. This inductive impedance limits the current in the lamp [2]. In the inductive impedance zone the inverter switches reach ZVS commutation in natural way. However, the turn-off is in hard switching, which decreases efficiency. The only way to improve the efficiency in the Class D inverter is working both ON-OFF zero current switching ZCS. But this means to work at the resonance switching where the resonant tank has close to zero impedance. So there is no way for limiting the lamp current.

In reference [3] proposed the input current shaper for both lamp current stabilization as well as to improve the power factor. Therefore, to limit lamp current and provide a stable operating point, the input DC-DC converter must control the current through the lamp accordingly to its dynamic characteristics. For example, if the input converter behaves as a voltage source the lamp will be supplied with a constant voltage AC square wave and the operating point will not be stable due to the dynamic negative impedance of the lamp [4].

An essential part of the study of lighting systems resides on the analysis of the lamp-ballast system interaction as a function of the stability [4]-[5]-[6]-[7]. To carry out this analysis it is necessary to know the dynamic behaviour of the lamp.

This paper presents the analysis and design of very efficient self-oscillating electronic ballast with power factor correction. As power factor corrector an input current shaper is used. The class D converter is working under both ON-OFF ZCS increasing the efficiency. The use of the input current shaper converters commonly used like power factor correctors [3], as stabilizer circuits of the discharge arc in self-oscillating electronic ballast working both ON-OFF ZCS is proposed in this paper. The analysis, simulation and experimental results of the lamp-ballast set together with an input current shaper converter are presented.

I. Description of the proposed ballast

Figure 1 shows the self-oscillating electronic ballast proposed. As can be seen, there are not integrated circuit. All the power switches are commanded through the self-oscillating circuit. The input stage is an input current shaper based on the fly-back converter. The output stage is a self-oscillating class D inverter working at resonance.

A. Analysis of the LCC resonant tank with ON-OFF ZCS

Traditionally, in resonant inverters for electronic ballasts the natural resonant frequency is lower than the switching frequency [8]. Under this condition, the resonant tank exhibits inductive impedance necessary for limiting the lamp current [9]. There is some draw backs in using inductive impedance for limiting the lamp current.

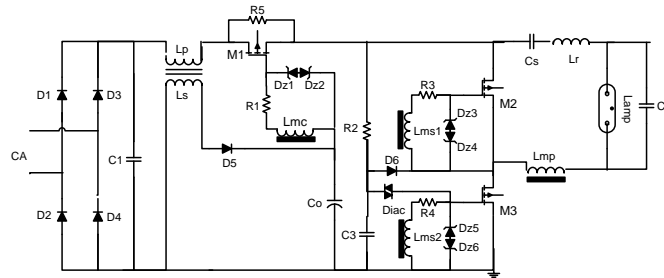

Fig. 1. Proposed Self-Oscillating electronic ballast.

For example, the load power factor is different to zero. So, there is higher circulating rms current which get higher both conduction and switching losses. In order to get the highest efficiency, it is desirable to work under ZCS during both switching ON and OFF. For the analysis, the *fundamental approach* is used considering a resistive behavior of the lamp and unitary load power factor [8] (figure 2).

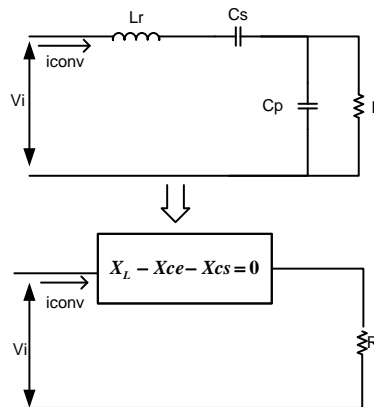

Fig. 2. Resonant tank ZCS ON-OFF

Table I summarizes the main design equations of the resonant tank.

TABLE I. DESIGN EQUATIONS FOR RESONANT TANK ZCS ON-OFF

C_p (Parallel capacitor)	$X_{cp} = \frac{V_i^2 \cdot V_{L(rms)}}{P_L \cdot \sqrt{2} \cdot V_{L(rms)}}$	(1)
C_e (Equivalent Capacitance)	$X_{ce} = \frac{X_{cp} \cdot R_L^2}{X_{cp}^2 - R_L^2}$	(2)
C_s (Series capacitance)	$X_{cs} = X_L - X_{ce}$	(3)

L_R (inductive resonant)	$X_L = Q \cdot X_{ce}$	(4)
Q (Factor of quality)	$Q > \frac{\sqrt{2V_L^2 \cdot Va^2}}{Va}$	(5)

C. Self-Oscillating Class D Converter

The self-oscillating converters do not use integrated circuit in the control stage, so they have few components count resulting the cheapest ballast.

The analysis of the inverter is carried out using the describing function method [2]. Figure 3 shows the block diagram of the system. This method is effective due very close to sinusoidal waveforms are presented. This is because of resonance operation.

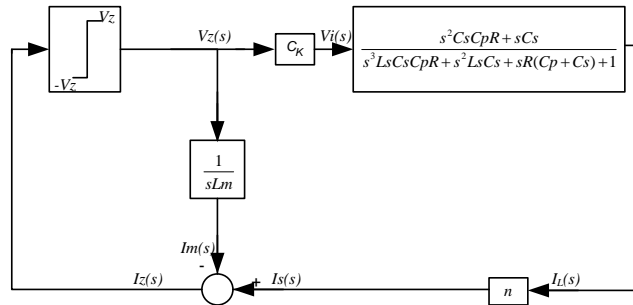

Fig. 3. Block diagram of the system

The resonant tank (resonance point) shows low-pass filter characteristics, resulting dominant first harmonic component (fundamental analysis is a good approach). The input of the system (I_z) is the magnetizing current minus the scaled sinusoidal current of the resonant tank. So, the zener current I_z is sinusoidal. Under these conditions linearization is possible based of the describing function. In our case, the describing function N is given by:

$$N = \frac{Y_1}{X} \angle 0^\circ = \frac{4M}{\pi X} = \frac{4 \cdot V_z}{\pi \cdot i_z} \quad (6)$$

Manipulating the block diagram of Figure 2 in order to reduce it to a single loop diagram block and reorganizing the equations, the final expression for L_m is:

$$L_m = \frac{L_s}{C_k \cdot n} \cdot \frac{\omega^6 - b\omega^4 + a^2\omega^4 - a\omega^2c - b\omega^4 + b^2\omega^2 - ca\omega^2 + c^2}{\omega^6 - b\omega^4 + a^2\omega^4 - a\omega^2c} \quad (7)$$

Where:

$$a = \frac{-1}{R \cdot C_p} \quad (8) \quad b = \left(\frac{1}{C_s \cdot L} + \frac{1}{C_p \cdot L} \right) \quad (10)$$

$$c = \frac{1}{R \cdot C_p \cdot C_s \cdot L} \quad (9) \quad C_k = \frac{E}{2V_z} \quad (11)$$

This equation is function of the resonant elements, the voltage gain and the zener voltage.

D. Input current shaper design

The input current shaper is a highly efficient converter which get high power factor. Figure 4

shows the equivalent circuit of the input current shaper supplying a resonant inverter. Table II summarizes the main design equations.

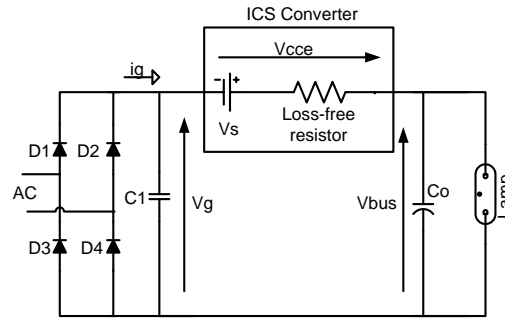

Fig. 4. Simplified equivalent circuit for ICS converter

TABLE II. DESIGN EQUATIONS FOR THE INPUT CURRENT SHAPER

<i>LFR (Loss free resistor)</i>	$R_s = \frac{\Pi_p \cdot 0.5 \cdot V_g}{P_e} (V_g - V_o)$	(12)
<i>Lp (Parallel inductive)</i>	$L_p = \frac{R_s \cdot D^2}{2 \cdot F_s}$	(13)
n	$n \leq \frac{V_o(1-D)}{(V_g - V_o)D}$	(14)
<i>Ls (Secondary inductive)</i>	$L_s = \left(\frac{V_{in_pico}}{V_{out}} - 1 \right)^2 \cdot L_s$	(15)

Figure 5 shows the diagram of the power flow in a typical system with two stages, the ICSC and the inverter, connected in cascade. In this system (figure 5(a)), the total efficiency is:

$$\frac{P_{Lamp}}{P_{total}} = \eta_{total} = \eta_{conv} \cdot \eta_{inv} \quad (16)$$

Where P_{total} is the input power delivered to the system, P_{lamp} is the lamp power, η_{total} is the efficiency of the system, and η_{conv} is the efficiency of the inverter.

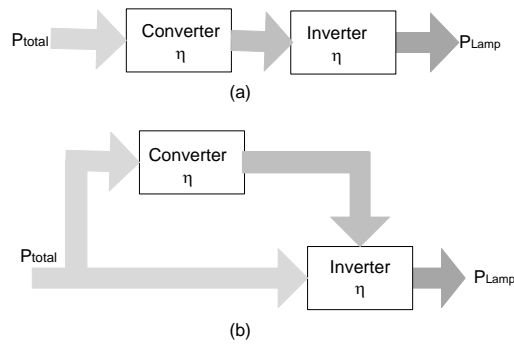

Fig. 5 Power distribution in the ICS converter

Fig. 5(b) represents the diagram of the flow power in the ICS converter. In this system the total efficiency is

$$\eta = \eta_{inv}[(1-m)(\eta_{conv} - 1) + 1] \quad (17)$$

The efficiency of the proposed ballast will always be greater than the traditional configuration of two stages connected in cascade

I. Stability criterion

In order to determine the stability of the system, certain conditions must be considered. In figure 6 can be observed that the lamp current is stabilized with an external impedance $Z_T(s)$ [10].

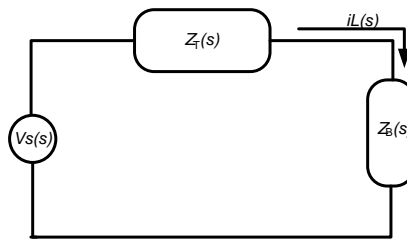

Fig. 6 Current limiter impedance in series with electronic ballast.

The external impedance $Z_T(s)$ is connected in serie with the resonant tank impedance $Z_B(s)$. The current transference function is:

$$i_L(s) = \frac{V_s(s)}{Z_T(s)} \cdot \frac{1}{1 + \frac{Z_B(s)}{Z_T(s)}} \quad (18)$$

According to the Nyquist criterion, the system is stable because the necessary stability condition $(1+(Z_B(s)/Z_T(s))<0)$ is fulfilled:

$$\frac{Z_B(s)}{Z_T(s)} < 1 \quad (19)$$

In this case, $Z_T(s)$ corresponds a loss free resistor (LFR) of the input current shaper and, $Z_B(s)$ is ballast working in resonance, therefore, $Z_B(s)$ it only corresponds to the equivalent resistance of lamp $Z_L(s)$.

However, it is clear that a lamp cannot operate with a high capacitance in parallel. This capacitance would act as a voltage source, making the lamp operation unstable [7]. Assuming a filter capacitor high enough to make the current ripple negligible, the converter can dynamically be modeled by a dc current source with a parallel capacitance, as show in Fig. 7.

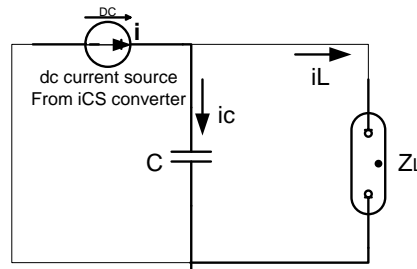

Fig. 7 Equivalent circuit ICS converter and lamp.

The output current of the ICS converter is determined by

$$i_{conv} = \frac{V_i^2 \cdot d^2}{2L_p f_s v_L} \quad (20)$$

The circuit of Fig. 6 can be expressed by the following differential equation:

$$C \frac{dv_L}{dt} + \frac{v_L}{z_L} = \frac{V_i \cdot d^2}{2L_p f_s v_L} \quad (21)$$

By applying small-signal perturbations, the following expression is obtained:

$$C \frac{d\hat{v}_L}{dt} + \frac{\hat{v}_L}{z_L} = \frac{V_i^2 \cdot D}{L_p f_s v_L} \hat{d} - \frac{V_i^2 \cdot D^2}{2L_p f_s v_L^2} \hat{v}_L \quad (22)$$

By using the Laplace Transform in (22):

$$\frac{\hat{v}_L}{\hat{d}} = \frac{2V_i^2 D V_L \cdot \hat{z}(s)}{(V_i^2 D^2 + 2CL_p f_s V_L^2 s) \cdot \hat{z}(s) + 2L_p f_s V_L^2} \quad (23)$$

In a previous work [10], a small-signal lamp model has been presented:

$$z_L(s) = k \frac{s + z}{s + p} \quad (24)$$

Substituting (24) in (23) and applying the Routh-Hurwitz criterion, the following expression is obtained:

$$C < \frac{(V_i^2 D^2 R_{lamp} + 2L_p f_s V_L^2)}{(2L_p f_s V_L^2 z R_{lamp})} \quad (25)$$

These are important conditions that must be fulfilled by the ballast in order to be stable.

The equation (24) can be used for characterizing a fluorescent lamp [11]. From (24), it is obtained the incremental impedance at low frequency (26) and high frequency (27). These can be expressed as:

$$z_L(s=0) = -r_d = \frac{k \cdot z}{p} \quad (26)$$

and

$$z_L(s=\infty) = R_{la} = k \quad (27)$$

The value of r_d y R_{La} can be obtained through the step response method. In Fig. 8, it is shown the lamp response when a power step is applied.

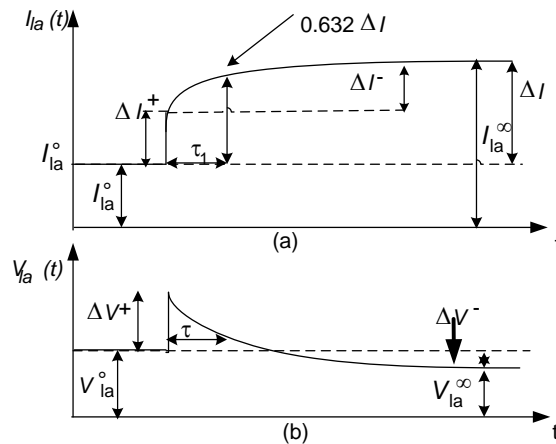

Fig 8. Measuring lamp parameters

In this case, the response curve $V-I$ a change of power during the step response method is graphed (Fig. 9).

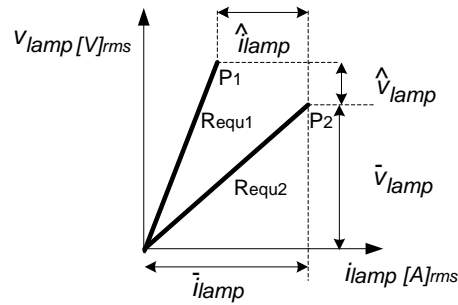

Fig.9 Response curve V-I a change of power

The R_{la} is the impedance lamp in steady stable, the values of v_{lamp} and i_{lamp} are obtained according to Fig. 2 and Fig. 3

$$R_{lamp} = k = \frac{\bar{v}_{lamp}}{\bar{i}_{lamp}} = \frac{\Delta V^{\infty}}{\Delta I^{\infty}} \quad (28)$$

Another equation that can be obtained from Fig. 2

$$r_d = \frac{\hat{v}_{lamp}}{\hat{i}_{lamp}} = \frac{\Delta V^-}{\Delta I} \quad (29)$$

The negative incremental impedance (r_d) is due to these small disturbances, which are result of small change in lamp impedance. Equalling equation (26) and (29) gives the next expression:

$$r_d = -\frac{\hat{v}_{lamp}}{\hat{i}_{lamp}} = \frac{k \cdot z}{p} \quad (30)$$

Thus, using (30), it is possible to determine the value of z (zero)

$$z = -\frac{\hat{v}_{lamp} \cdot p}{k \cdot \hat{i}_{lamp}} \quad (31)$$

The gas thermal constant is the dominant constant in the lamp dynamic, which is extracted from the lamp current [11]. The pole is:

$$p = \frac{1}{\tau} \quad (32)$$

The lamp time constant (τ) is measured (current) since the step is applied until the response reaches 63% of the step magnitude (Fig. 8)

II. Design example

This section shows a design example and some experimental results of a laboratory prototype for 32 watts circular lamp.

A. Design example.

The input voltage is the American line (120 V_{rms} , 60 Hz). The minimum bus voltages permitted for the standard IEC1000-3-2 norm is 76 volts, and then 60 volts is considered. Also, the switching frequency is 50 KHz.

1) Resonant elements design

By using the equations of Table I and considering a quality factor of 2.5 are obtained the next values: L_r (*Inductive resonant*)= 221 μ H, C_p =47nF and, C_s =330nF. For the self-oscillating circuit a V_z =12 volts and n =6 are considered. So, the magnetizing inductance (equation 7) is L_{m_s} =262 μ H and I_{m_p} (primary) is 7.28 μ H.

2) Input current shaper converter

As the input current shaper switch is commanded by an extra winding of the self-oscillating, the switching frequency is also 50 kHz. According equations 12-15 (Table II), the ICS converter values are: R_s =295 Ω , L_p =738 μ H, and L_s =148 μ H.

3) Stability of the system

In order to evaluate the lamp parameters, a power step is applied to the lamp. The experiments were done a power step on interval from 70% to 100% of nominal power. In the Figs. 10 and 11 experimental waveforms during the step response are shown.

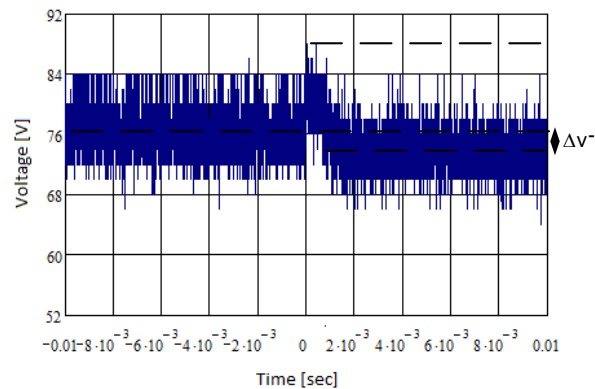

Fig. 10. Lamp voltage response to step

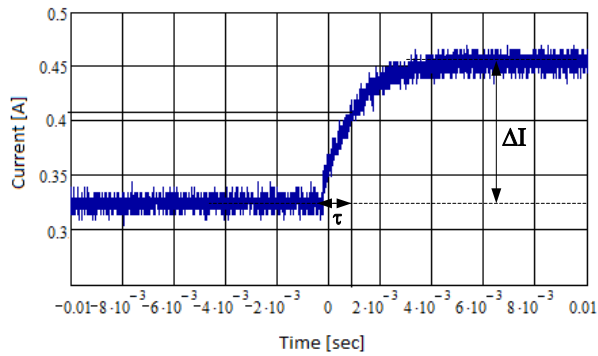

Fig.11. Lamp current response to step

The corresponding values of the lamp parameters are shown in the Table III.

TABLE III. LAMP PARAMETERS

Data from lamp voltage	Data from lamp current
$V_{lamp}^o = 76.1V$	$i_{lamp}^o = 0.439A$
$\Delta V^- = 72.9V$	$\Delta I = 0.127A$
	$\tau = 1.2ms$

Substituting parameters in (28), (29) and (32), $R_{lamp} = 179.04\Omega$, $r_d = -25.2$ and $p = 820$. The maximum value of the capacitor that ensures stable operation is $C_o < 446\mu F$ (equation 25)

I. Experimental results

Figure 12 shows the ON-OFF ZCS condition. The load power factor is unitary and minimum circulating currents are presented. The resonant tank is working under ON-OFF ZCS increasing the efficiency. The efficiency at this stage is 98%.

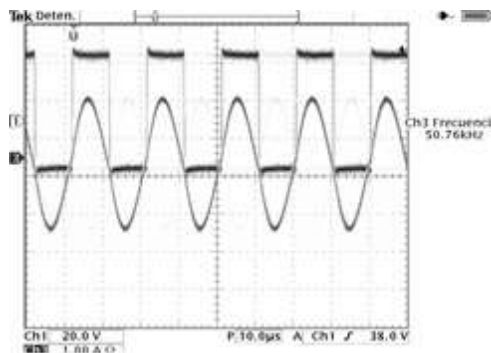

Fig. 12. ON-OFF ZCS commutation

Figure 13 shows lamp voltage and current waveforms in the lamp, additionally observed stable system behavior.

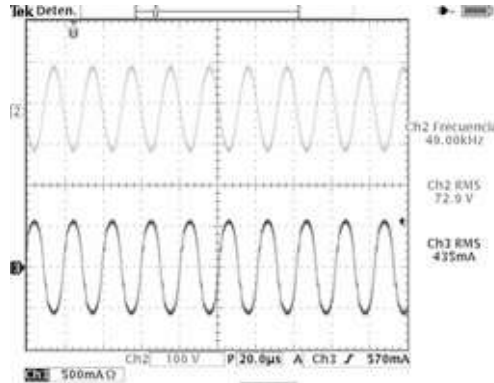

Fig. 13 Lamp voltage and current waveforms

The total efficiency of the circuit is determined by the following expression:

$$\eta_{TOT} = \frac{P_{lamp}}{P_{ent}} = \eta_{inv}(1-k) + \eta_{inv}\eta_{conv}k \quad (33)$$

Where, $\eta_{conv}=83$ (ICS converter), $\eta_{inv} =0.98$ (resonant inverter) and $k=0.5$ (duty cycle). Therefore, the total efficiency is $\eta=90$.

Figure 14 shows input voltage and current waveforms. The input current waveform fulfills the IEC1000-3-2 norm. The THD was 28% and the power factor 97%.

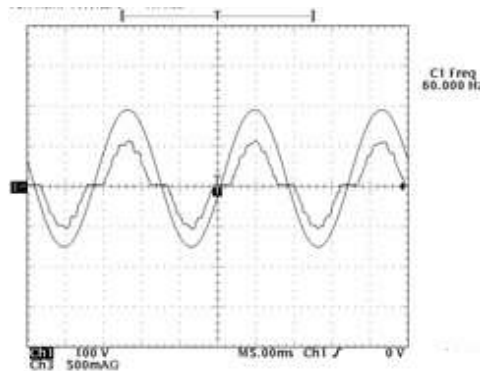

Fig.14 Input voltage and current waveform

I. Conclusions

This paper presents a low-cost high-efficient self-oscillating electronic ballast with high power factor. The power factor correction is realized by an input current shaper where the power switch is commanded by an extra winding in the self-oscillating circuit. Besides, the input current shaper works as lamp current limiter stabilizing the lamp. So, there are not any integrated circuits.

The analysis of the self-oscillating circuit is carried out using the describing function. The experimental results show a very good performance on power factor, THD, and efficiency.

References

E. Flores, M. Ponce, L.G. Vela, M.A. Juárez, L. Hernandez, "Analysis and Design Method for High Frequency Self-Oscillating Electronic Ballasts", IEEE Transactions on Industry Applications, Vol.4 No.6 Nov. 2011. pp. 2430–2436

Prado R. N., Seidel A. R., Bisogno F. E., and Pavão R. K., "Self-Oscillating Electronic Ballast Design based on Point of View of Control System", ThirtySixth IAS Annual Meeting. Conference Record of the 2001 IEEE

J. M. Alonso, A.J. Calleja, E. López, J. Ribas, M. Rico; "Analysis and experimental results of a singlestage high-power-factor electronic ballast based on flyback converter," IEEE APEC'98 proceedings, pp. 1142-1148

Mario Ponce, Efrén Flores, Mario A. Juárez, Víctor H. Olivares. "Stabilization of HID Lamps using Dc-Dc Converters with an Open Loop Control". IEEE Transactions on Power Electronics, Vol. 22, No. 3, May 2007. pp. 769-779.

J. Ribas, J. M. Alonso, A. J. Calleja, E. Lopez, J. Cardesin, J. Garcia, M. Rico. "Arc stabilization in low-frequency square-wave electronic ballast for metal halide lamps". IEEE Applied Power Electronics Conference and Exposition, 2003. APEC '03. Volume 2, 9-13 Feb. 2003 Page(s):1179 – 1184

Ben-Yaakov, S., et al., "Statics and Dynamics of Fluorescent Lamps Operating at High Frequency: Modeling and Simulation" IEEE Transactions on Industry Applications, 38(6):1486-1492, 2002.

Alonso, J.M, Dalla Costa, M.A, Cardesín, J. Martin-Ramos, J.A.Garcia-Garcia, J. "Small-Signal Modeling of Discharge Lamps Throught Step Response and Its Aplication Low-frequency Square-Waveform Electronic Ballast" Power Electronics; Volumen 22, Numer 3, Pag 744-752 May 2007.

J. Correa, M. Ponce, A. López, J. Arau, J.M. Alonso "A Comparison of LCC and LC Filters for its Application in Electronic Ballast for Metal-Halide Lamps" PESC 2001, record.

Mario Ponce, Mario A. Juárez, Rene Osorio, Víctor H. Olivares. "Self-Oscillating Ballast with High Power Factor and High Efficiency with no Integrated Circuits". I International Conference on

Electrical and Electronics Engineering, X Conference on Electrical Engineering, Acapulco, México, 8-10 September 2004

Edward E.Deng "Negative incremental Impedance of stability of fluorescents lamps and simple high power factor lamp ballast" Thesis Doctoral, California Institute of technology, Pasadena California, 1996

M. A. Juárez, M. Ponce-Silva, J. E. Arau and E. Flores "A Simple Method to Obtain the Coefficients of Small Signal Model for Discharge Lamps" IEEE International Conference on Power Electronics CIEP'10, 22-25 August 2010. San Luis Potosí, México.